

S

s



Five empty rectangular boxes for writing.

Lös kryssen

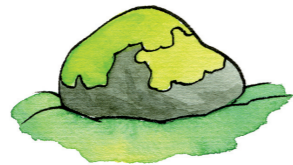
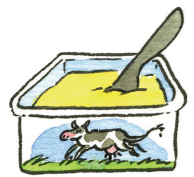
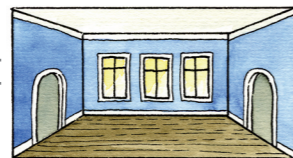
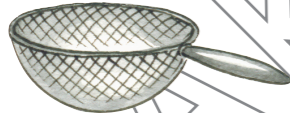
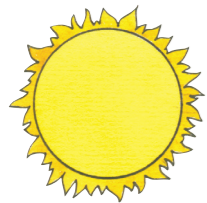
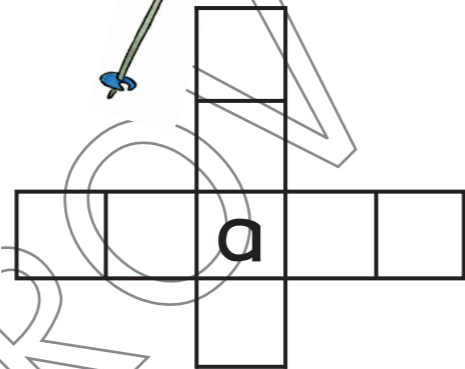
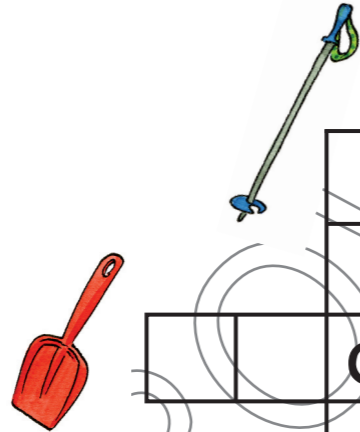
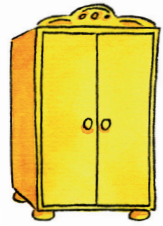
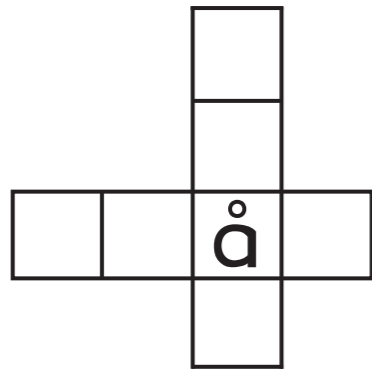

# Spökslottet



- 1. skelett
- 2. stige
- 3. sten
- 4. svärd
- 5. svamp
- 6. spöke
- 7. slott
- 8. skatt
- 9. solros
- 10. spindel

Aa	Bb	Cc	Dd	Ee	Ff	Gg	Hh	Ii	Jj	Kk	Ll	Mm	Nn

Oo	Pp	Qq	Rr	Ss	Tt	Uu	Vv	Ww	Xx	Yy	Zz	Åå	Ää	Öö



U

u

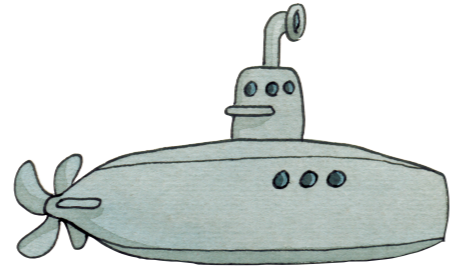
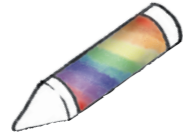

□ - □ □ □ □

Rimma



hund

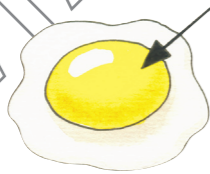
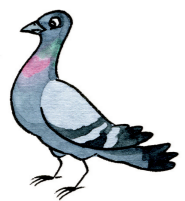
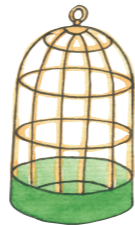
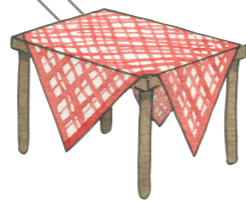
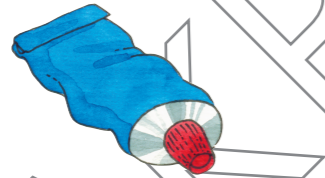

# Hur många?

~~ett~~  
två

tre  
fyra

fem  
sex

sju  
åtta

nio  
tio



ett



bär

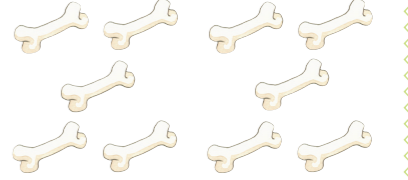
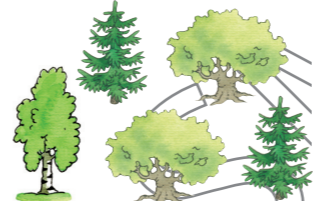
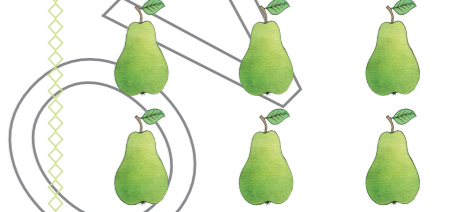
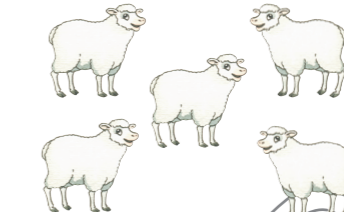
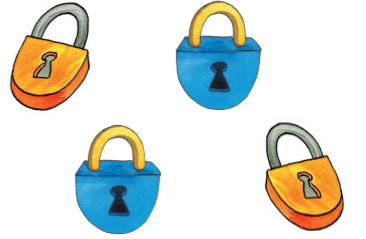

Aa	Bb	Cc	Dd	Ee	Ff	Gg	Hh	Ii	Jj	Kk	Ll	Mm	Nn

Oo	Pp	Qq	Rr	Ss	Tt	Uu	Vv	Ww	Xx	Yy	Zz	Åå	Ää	Öö

# Till Läraren

I BokstavsOrdboken ORD tränar barnen på att läsa och skriva enkla ord utan stöd.

Med hjälp av alfabetsremsan längst ner på varje sida kan barnen lista ut hur orden ska stavas. Dessutom stimuleras läsinlärningen av roliga, kluriga och omväxlande övningar av olika slag.

Denna bok är en fristående fortsättning på BokstavsOrdboken A-Ö där barnen tränar på att framför allt skriva bokstäverna i ord med stöd av en ordbank.

Längst fram i denna bok finns en nyckel till Handalfabetet som kan kopieras och förstoras och sättas upp. Där finns också Mitt protokoll där barnen och läraren kan bokföra sitt BokstavsOrdsarbete. Handalfabetet kan för många barn vara en hjälp och ytterligare en förstärkning i bokstavs-inlärningen. Förutom att de ser och hör bokstaven (visuell och auditiv inlärning) så stimulerar handalfabetets bokstäver inlärningen motoriskt.

Barnen kan välja i vilken ordning de vill arbeta med bokstavsorden. Boken har ingen stegrad svårighetsgrad. Vissa bokstäver är emellertid lättare och mer frekventa och därför kan man föreslå en ordning på bokstavsorden för barn som så behöver t.ex. O, S, I, L, A, M, R, V osv.

**LYCKA TILL!**

*Karin Danielsson*